

Custom DOAS with Enthalpy Wheel, 105 Tons Packaged DX and 28K CFM

MARKET: Commercial

Designed for a commercial highrise, this XeteX custom DOAS features an enthalpy wheel with full season controls and 100% outdoor air. It includes packaged DX, indirect gas fired furnace, hotgas reheat, sound dampening perf liners, and high efficiency filters providing year-round climate control and indoor air quality.



| | |
|-------------------------------------|--|
| Model: | AVR-3200-RT-DX-HG-HI-FF-AC |
| Dimensions: | 142"H x 360"L x 144"W |
| Weight: | 29,500 lbs |
| Supply CFM: | 27,816 CFM |
| Energy Recovery: | Enthalpy Wheel |
| Energy Effectiveness: | Winter: 85% / Summer: 83% |
| Heating Types/ Heating Capacity: | Ind. Fired Furnace: 1,621 MBH Hot Gas Reheat: 487 MBH |
| Cooling Type: | Packaged DX Cooling |
| Cooling Capacity: | 105 Tons |

CONSTRUCTION

- Outdoor unit; double wall **thermal break construction** with 2" injected foam (R-value 14) insulation
- 18ga galvaneal outer casing and acrylic paint
- 18ga galvanized interior casing
- Welded 8" structural steel base frame and lifting lugs with acrylic paint
- 0.050 alum. floor with 2" injected foam (R-14) insulation
- 304SS drain pan

FEATURES

- **Factory mounted controls**
- **Enthalpy wheel** with full season controls
- **Integral air-cooled section with multiple staged compressors and VFD lead**
- **1/8" alum. tread plate floor**
- **20ga perf. liner** included in the SA/EA fan sections for sound dampening

COMPONENTS

- A. OA 2" MERV 8 filters with galv. rack**
- B. Enthalpy wheel**
- C. SA 4" MERV 14 with galv. rack**
- D. DX Evap coil**
- E. Hot gas reheat coil**
- F. SA premium three plenum fan array**
- G. 409SS indirect gas fired furnace**
- H. RA 2" MERV 8 filters with galv. rack**
- I. EA premium two plenum fan array**
- J. Condensing section**

Contact XeteX for your next Custom DOAS!

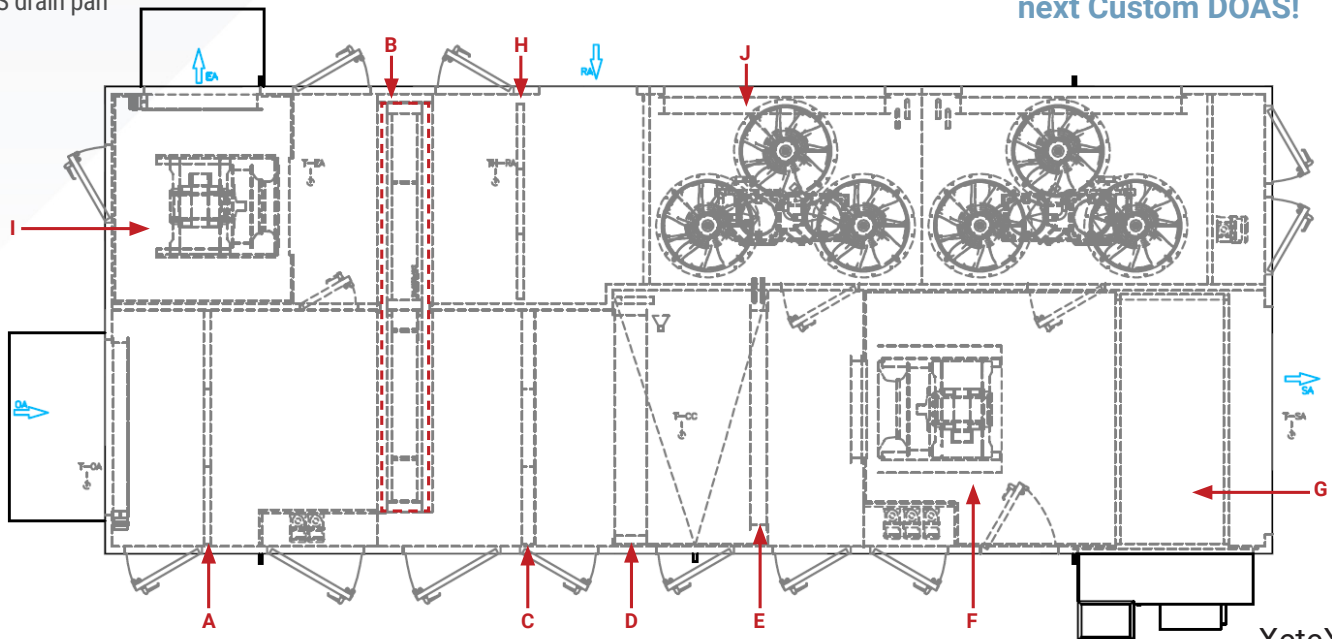

XeteX.com